

ALL ABOUT E

Are SMEs missing an opportunity?

Just 18% of SMEs are selling on-line. Less than one percent of those derive all of their sales through the Internet. But 90 per cent of companies with ecommerce operations said their site was profitable and the value of Internet sales rose by 56 per cent between 2004 and 2005, from £66.2bn to £103.3bn.

So lets take a look at E and see if SMEs should be less fearful.

E = Electronic



The "E" prefix can be attached to anything that has moved from the physical world to its electronic alternative. Most "E" words have now become synonymous with the Internet.

Let's look at some.

ECRM uses the Internet and other digital media (e.g. SMS, DRTV) to manage the relationship with customers. You have ECRM requirements if you interact with customers using any electronic medium.

EBusiness is more than just ECommerce. EBusiness refers to any business process that relies on a computer system. You are in EBusiness if you have any business process that relies on a computer system.

ECommerce uses the Internet / WWW consists for the buying and selling of products or services.

EMarketing is marketing that uses the Internet to reach a niche or a global audience with instant response and includes search engine marketing, display advertising, EMail marketing, affiliate marketing, interactive advertising and viral marketing.

ECRM, EBusiness, Ecommerce and EMarketing can be conducted using the WWW, the Internet, intranets, extranets, or some combination of these to enable companies to:

- link their computer systems more efficiently and flexibly
- work more closely with suppliers and partners
- satisfy customer service needs and expectations better

Customer relationship management (CRM) is important to every business. ECRM uses the Internet / WWW as a tool to help with CRM.

ECRM

ECRM is about understanding customers' needs to increase sales and improve service by unifying a company's activities around the customer. The goal is to increase customer share and customer retention through customer satisfaction. Some people get concerned that using the Internet to manage relationships with customers takes away the personal touch.



But using appropriate technology on your website (or elsewhere) can improve your personal touch with your customers – see live chat at www.innovantage.co.uk as an example and using the Internet for ECRM also helps automate the process of managing your dealings with customers, freeing up time to spend with them face-to-face and on the telephone.

In addition to this the information from ECRM whenever a customer visits the website or sends an email, based on software that tracks and records pages they looked at, what information they downloaded and the topic of any email they might send can be stored in a database. This gives detailed customer profile and trend information and can be cross-referenced to generate reports, customer lists, individual preferences, the last time there was communication between you and them, what it was about and a great deal more.

This can be used to personalise communication with customers and alert them to special offers or inform them of new services and products in a timely and relevant way.

EBusiness

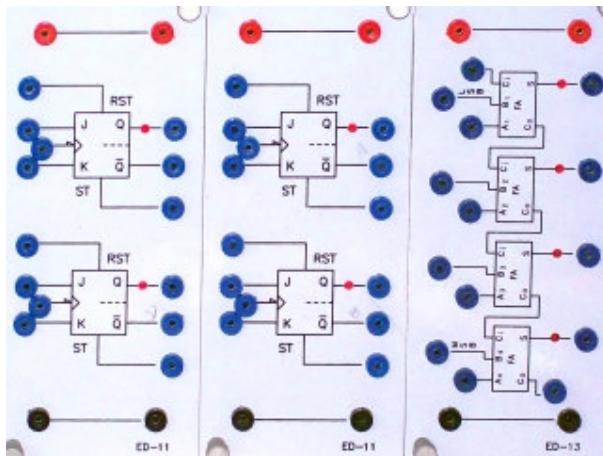

EBusiness is about the processes across the entire value chain:

- electronic purchasing and supply chain management
- processing orders electronically
- handling customer service
- cooperating with business partners

EBusiness allows the integration of intra and inter firm business processes via intranets and extranets.

An intranet is a private computer network that uses Internet methods to securely share between staff and can provide new user interfaces with corporate "legacy" data and information systems. It's "a private Internet". In this way off-site

employees can access company information, computing resources and internal communications.

An extranet can generally be accessed by customers, suppliers, or other approved parties.

Both intranets and extranets do not have to allow any access to the organization's internal network as access can be provided through a gateway with a firewall, user authentication, encryption of messages etc.

ECommerce

ECommerce has grown dramatically in the last few years. For example the Office of National Statistics (ONS) report on Ecommerce for 2005 says: "The value of Internet sales rose by 56 per cent between 2004 and 2005, from £66.2bn to £103.3bn, while the proportion of businesses selling on-line rose by 22 per cent from 12 per cent of businesses to 14.6 per cent of businesses."



Unfortunately it appears that many small and medium sized businesses are not getting involved.

ONS LINK:

[http://www.statistics.gov.uk/downloads/theme_economy/ecommerce_report_2005.pdf]

The Federation of Small Businesses (FSB) has highlighted the significant numbers of small and medium sized enterprises (SMEs) being deterred from e-commerce, following a report by the House of Lords Science & Technology Committee. Despite the fact that the geographical reach of the Internet makes it possible for SMEs to compete in the global market at low cost, just 18% of SMEs are selling on-line. Less than one percent of those derive all of their sales through the Internet.

This contrasts with research carried out by Actinic which shows that ECommerce is more profitable and affordable than ever before - though few SMEs are taking advantage of it.

The survey showed that in 2006, 90 per cent of companies with ecommerce operations said their site was profitable - up from 70 per cent in 2005 - an all-time high.

The survey [[http://www.actinic.co.uk/Actinic Ecommerce Report 2006.pdf](http://www.actinic.co.uk/Actinic_Ecommerce_Report_2006.pdf)] also revealed that:

- the proportion of retail companies using ecommerce rose from 8% in 2005 to 11% in 2006
- 75% of retailers who accept mail and telephone order still do not have an ecommerce facility



- of the companies that don't already operate an ecommerce service, 20 per cent are planning to start. Of the remaining companies, two-thirds are still not planning to introduce ecommerce, with 10 per cent stating they were unsure
- the main reasons cited for ignoring ecommerce were the unsuitability of products (38 per cent) or a lack of demand (17 per cent)

You can read more about Ecommerce at <http://www.e-crm.co.uk/profile/newsletter-downloads/About-ECommerce.pdf>

EMarketing

EMarketing uses the same concepts as traditional marketing. The purpose is to devise strategies in order to deliver your message to your target market. EMarketing tends to be affordable and less effort intensive than traditional marketing and so produces tremendous ROI results which mean it is ideal for small and medium-sized businesses.

The difference with EMarketing lies in the options available. You can find out more at these URLs:

Search engine optimization:

http://www.e-crm.co.uk/interactive_marketing/ecrm_search_engine_positioning_optimisation.php
http://www.e-crm.co.uk/essays/ecrm_essay_search_engine_positioning_optimization_submission.htm

Pay per click:

<http://www.e-crm.co.uk/profile/message171106.html>
http://www.e-crm.co.uk/interactive_marketing/ecrm_pay_per_click_marketing.php

Email:

<http://www.e-crm.co.uk/profile/message210507.html>
http://www.e-crm.co.uk/interactive_marketing/ecrm_email_marketing.html